

Development of the rice-powder manufacturing system using underwater shock wave

K. Shimojima^{1,*}, Y. Miyafuji², K. Naha¹, O. Higa², R. Matsubara³, K. Higa³, Y. Higa¹, T. Matsui³, A. Takemoto⁴, S. Tanaka⁴, H. Maehara⁴ and S. Itoh⁵

¹Department of Mechanical Systems Engineering, Okinawa National College of Technology, 905 Henoko, Nago city, Okinawa 905-2192, Japan

²Technical Support Section, O.N.C.T, 905 Henoko, Nago city, Okinawa 905-2192, Japan

³Department of Information And Communication System Engineering, O.N.C.T, 905 Henoko, Nago city, Okinawa 905-2192, Japan

⁴Shock Wave and Condensed Matter Research Center, Kumamoto University, 2-39-1 Kurokami, Kumamoto City, Kumamoto 860-8555, Japan

⁵O.N.C.T, 905 Henoko, Nago city, Okinawa 905-2192, Japan

ABSTRACT

Self-sufficiency in food is very low (about 40%) in Japan. Therefore, the rice powder is paid to attention because it can be processed to the udon (noodle) and bread etc. We has already developed the rice-powder disintegrator using the underwater shock wave by the electrode. But it has not been cleared what is the most suitable pressure vessel. The purpose of this study is to investigate the most suitable configuration of the pressure vessels for manufacturing the rice-powder using the underwater shock wave. Experimental conditions to manufacture the rice-powder (particle size is 100 μm) is clarified using this device. Moreover, the manufacturing efficiency of the rice-powder, the relation between the number of the shock wave generation and the grain degree of rice-powder is clarified.

1. INTRODUCTION

Recent years, the consumption of the rice is decrease from 13.41 million tons in 1963 to nine million tons in Japan. Therefore, the rice-powder is paid to attention, because it can be processed to the udon (noodle) and bread etc. Figure 1 shows comparison of flour milling of conventional method and underwater shock wave. The typical manufacturing method of the flour milling rice-powder is contact destruction using the hard material. Therefore, the rice-powder manufacturing generates heat, and the quality of rice-powder is deteriorated. And to easily crushed rice is immersed by water. However, a lot of energy is necessary to dry rice and, miscellaneous germs breed by immersing by water.

On the other hand, the flouring technology of food that uses the underwater shock wave has been researched [1]. The destruction of food doesn't accompany generation of heat

*Corresponding author. E-mail: k_shimo@okinawa-ct.ac.jp

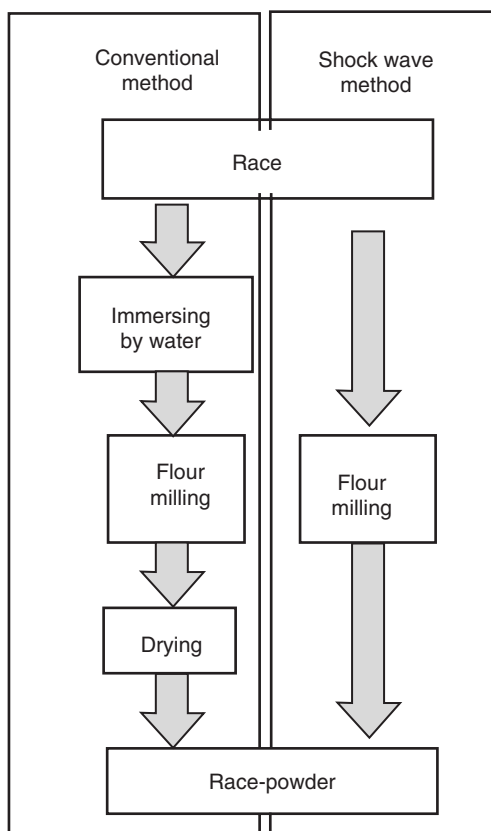

Figure 1 The comparison of methods of manufacturing the rice-powder.

because the underwater shock wave propagates at very fast speed more than the sound speed. Moreover, it is clear that food is sterilized by the shock wave [2]. So we have already developed the rice-powder disintegrator using the underwater shock wave by the electrode. But it has not been cleared what is the most suitable pressure vessel. Moreover, the manufacturing efficiency of the rice-powder, the relation between the number of the shock wave generation and the particle degree of rice-powder is clarified.

2. RICE-POWDER MANUFACTURING SYSTEM

Figure 2 shows the composition of the rice-powder manufacturing system. The explanation of this system is divided into five devices.

1. The rice-powder disintegrator
2. The rice and the rice-powder transportation device
3. The automatic sieve device
4. The power supply circuit device
5. The device of the supply and the drain water

All devices of this manufacturing system are packaged by one rack (This system is able to moved easily). Height is 1200 mm, width is 1800 mm, and the depth is 600 mm. It is possible to operate in a usual home power supply.

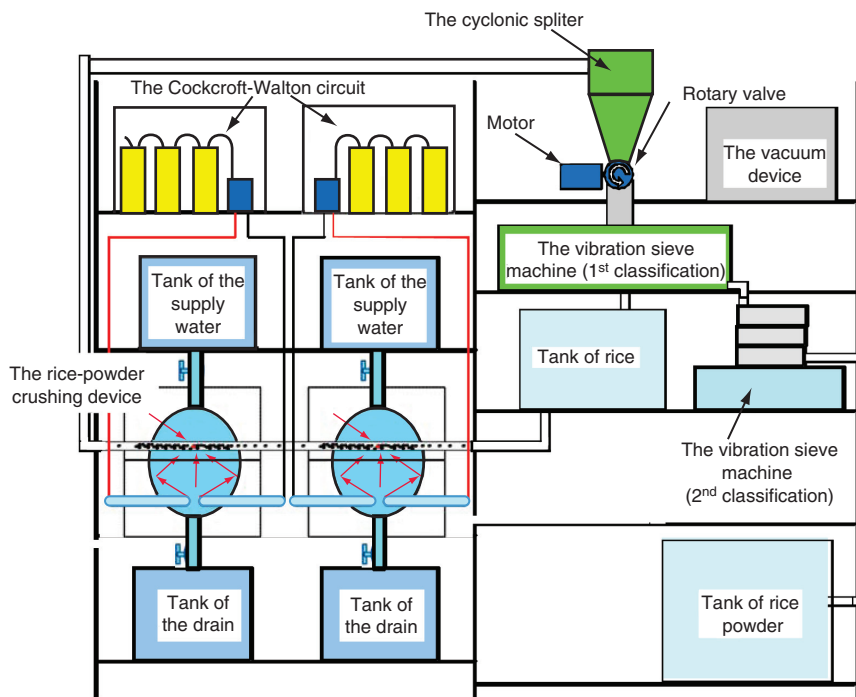

Figure 2 The Picture of rice-powder manufacturing system.

2.1. THE RICE-POWDER DISINTEGRATOR

Figure 3, 4 shows picture of the disintegrator.

A necessary function of the disintegrator is shown below.

1. To improve the destruction energy by the shock wave, water is filled with the inside.
2. The copper electrode to generate shock wave
3. Pressure vessel that endure high pressure attributable by the underwater shock wave.

The manufacturing system has the electrode to generate the shock wave. The rice which is the appropriate amount comes to be inserted in the silicone hose sequentially by the traffic department.

And then the rice is continuously manufactured rice-powder by the underwater shock wave.

2.2. THE RICE AND THE RICE-POWDER TRANSPORTATION DEVICE

To enable the milling flour by full automation, the function of supply rice and the rice powder to the crushing and classification device is necessary. Figure 5 shows the structure of the transportation device. The transportation device consists of the cyclonic splitter, the vacuum device, the rotary valve and the aspirator. The rotary valve doesn't pass air, and passes only rice. And then, all air in cyclonic is breathed in to the suction unit. So, it is possible the crushed rice-powder and inhalation air are divided by cyclonic splitter. Rice doesn't flow backward to the inlet using aspirator, and the rice of an appropriate ratio and air are supplied to the rice disintegrator device. The higher the density of the rice supplied to the disintegrator device is the more the crushing ability.

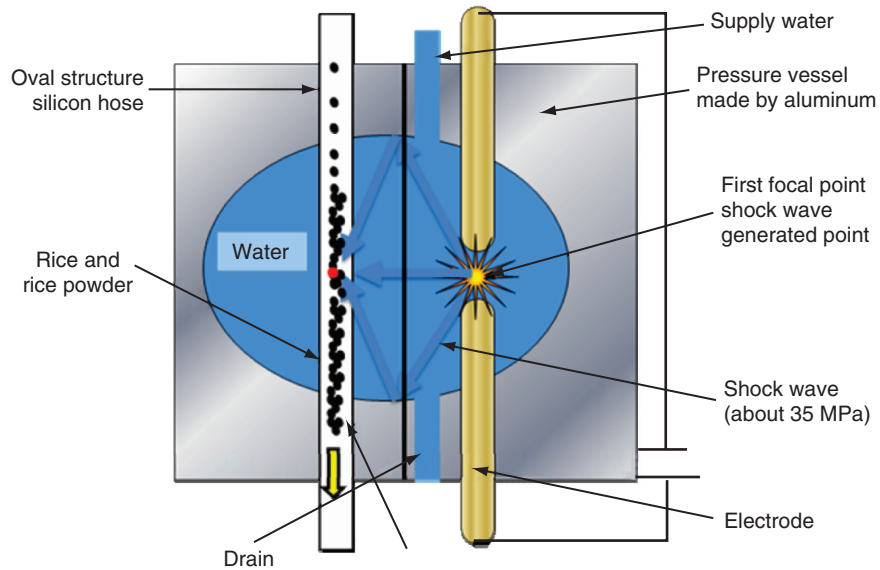

Figure 3 The cross section of the disintegrator.

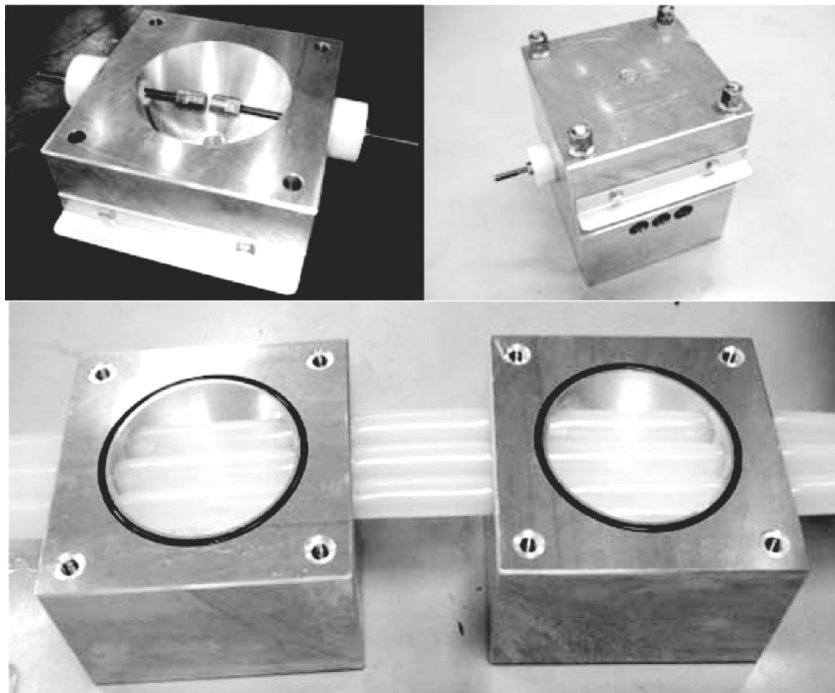

Figure 4 The photographs of the disintegrator.

However, when the density is too high, rice is blocked in the transportation system. And then the amount of the supply of rice is adjusted by changing the rotational speed of the rotary valve. So the rice and rice-powder is transported constant.

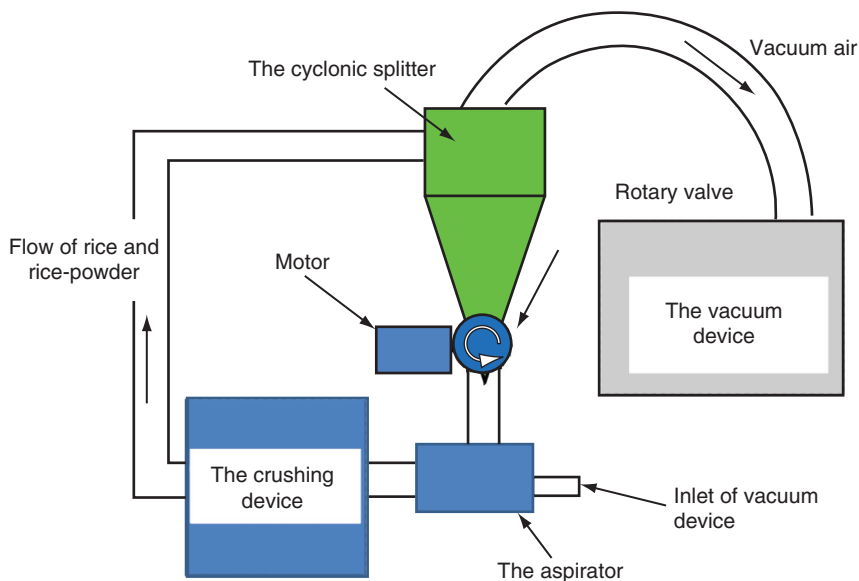

Figure 5 The picture of the transportation device.

2.3. THE AUTOMATIC SIEVE DEVICE

The size of the powder of the rice-powder demanded with the processing object of food is different. The rice powder is divided into the different grain size with two vibration sieve machine. Figure 6 shows the structure of vibration sieve machine. This device divides the rice and the rice powder with 100 μm grain size. This device has amount of classification ability more than the amount of the supply of rice with the rice-powder transportation device.

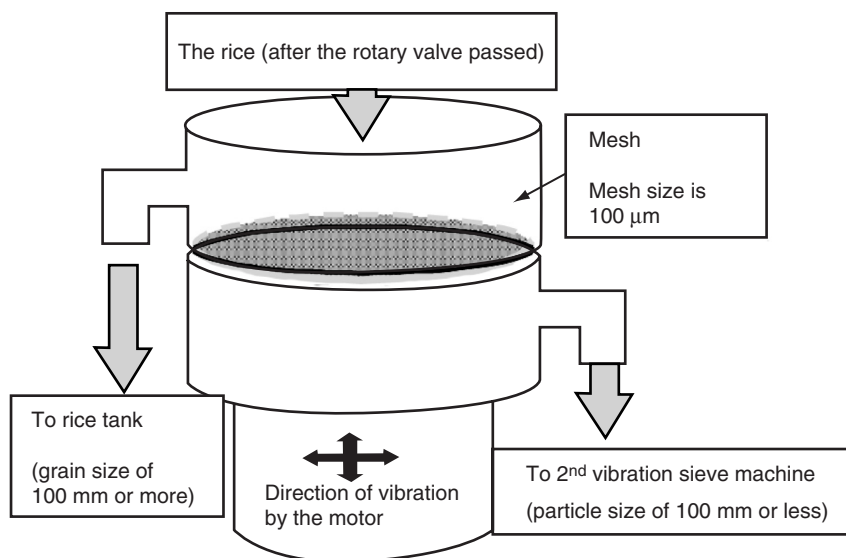

Figure 6 The structure of vibration sieve machine.

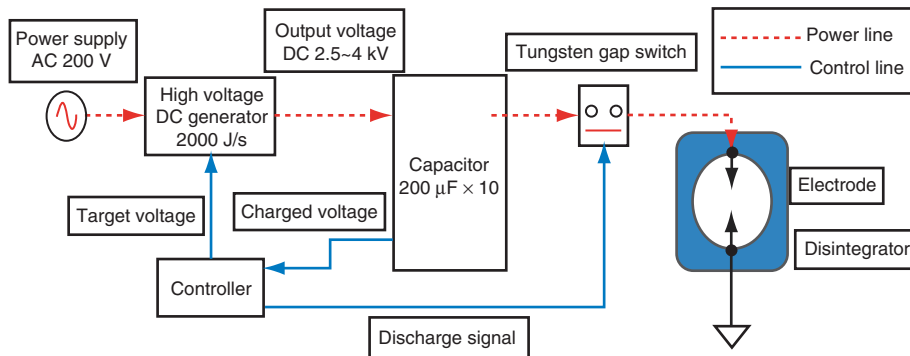

Figure 6 Capacitors and diodes in Cockcroft-Walton circuit.

This device can supply the traceable rice-powder because sieve mesh size is measured according to ISO.

2.4. THE POWER SUPPLY CIRCUIT DEVICE

Figure 6 shows the power supply circuit device, this device can generate energy 2000 J/sec. Electricity is accumulated to ten capacitors, and it is discharged in the disintegrator using the gap switch. Because the shock wave generation energy is calculated with $1/2 cv^2$, it is possible to generate the shock wave by the electrical discharge energy of maximum 12.5 KJ.

2.5. THE DEVICE OF THE SUPPLY AND THE DRAIN WATER

The copper tungsten is used for the electrode to generate the underwater shock wave. The element of the electrode melts to water every time the shock wave is generated. The electro conductive of water rises if copper melts in water, and the generation energy of the shock wave is obstructed. Therefore, water in the rice-powder disintegrator has to always circulate, and be clean. We paid attention to electrical discharge machine to divide water and copper. Electrical discharge machine is using the copper electrode in water. The filter of electrical discharge machine is used for the removal of the underwater copper element in the rice powder disintegrator. Figure 7(a) shows the structure of supply and drain water device. The stepping motor is set up on the valve of the supply and drain to the rice powder disintegrator. Figure 7(b) shows the flow of operation of this device. Internal pressure rises very much when the shock wave is generated in the disintegrator. Therefore, the valve has to shut when the shock wave is generated. Moreover, the voltage for the shock wave generation is dangerous for man. And then it is necessary to open and shut the valve in the automatic operation. The valve is opened and shut by using the sequencer by the automatic operation when the power supply device is charged, and the water circulates to the supply tank with the water pump via the filter. The clean water is able to be supplied at any time using this device in the disintegrator.

3. RESULTS AND DISCUSSION

The rice powder is manufactured using this rice powder manufacturing system. The grain size of the rice-powder that the vibration sieve machine (1st classification) passes is measured by grain size measuring machine. Figure 8 shows the result of grain size on rice powder. The vertical axis is the volume and the horizontal axis is grain size of the rice-powder. As a result,

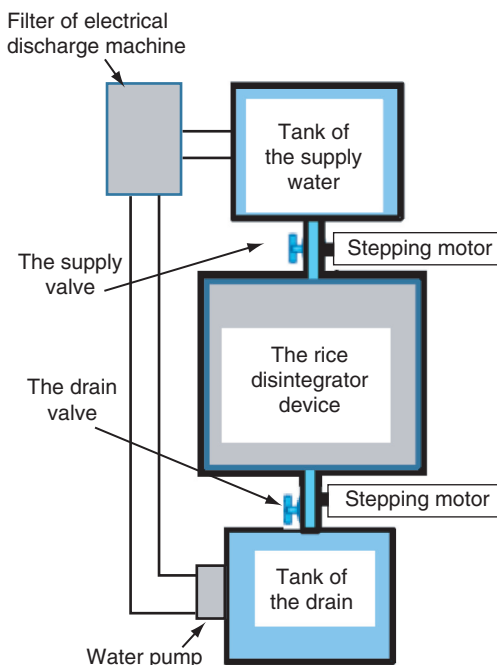

Figure 7 Structure of supply and drain device.

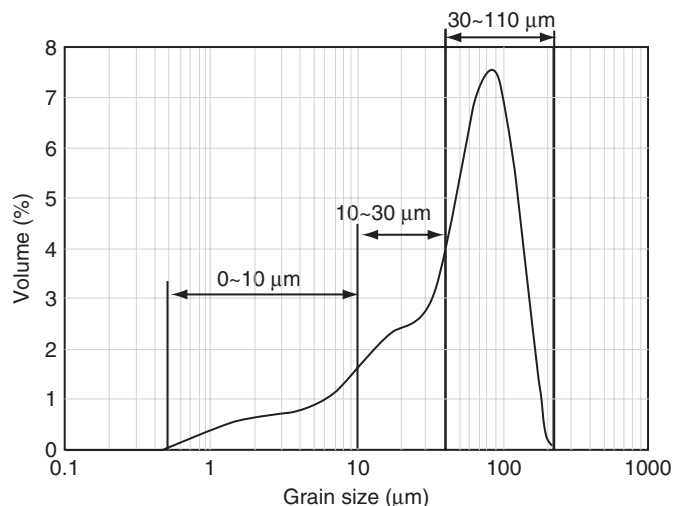

Figure 8 The result of grain size on rice powder.

grain size is divided to three group (0–10 µm, 10–30 µm, and 30–100 µm). It is clear that the grain size is uneven, in this reason that the rice is crushed at random by the shock wave. The grain degree corresponding to food that processes the rice powder can be offered by using the detailed mesh. On the other hand, it is clear that the grain size (30–100 µm) of the rice-powder of 87% is able to be manufactured. And the average of this grain size is 59 µm. The

relation of the value of the grain degree peak of the size of the mesh used and the obtained rice-powder will be clarified in the future. The manufacturing efficiency of the rice-powder of 100 mm is measured by preparing a uniform rice-powder of 250 mm in the particle size, and using five times shock waves. As a result, it is clear that about 35.4% of rice is manufactured to rice powder. The relation between the generation frequency of the shock wave and the manufacturing efficiency of the rice-powder will be clarified in the future.

When rice is processed to the powder, because the processing by the shock wave is a mechanism that the inside of rice is crushed, the particle size of the rice-powder is different. Therefore, to evaluate the amount of the milling flour quantitatively, the grain degree (100 μm) and the mass (150 g) of the crushed rice are constant. Figure 9 shows the amount of the milling flour on five shock waves. The horizontal axis shows the energy to generate the shock wave and the vertical axis shows the amount of the milling flour. Time in figure is the charging time of energy that generates the shock wave. It is clear that, the amount of the milling flour improving when the energy improved. Figure 10 shows the amount of the milling flour per hour. The horizontal axis shows the energy of the shock wave, the vertical axis shows the amount of the milling flour per hour calculated by batch experimentation. It is clear that the rice-powder manufacturing efficiency is 450 g/hour.

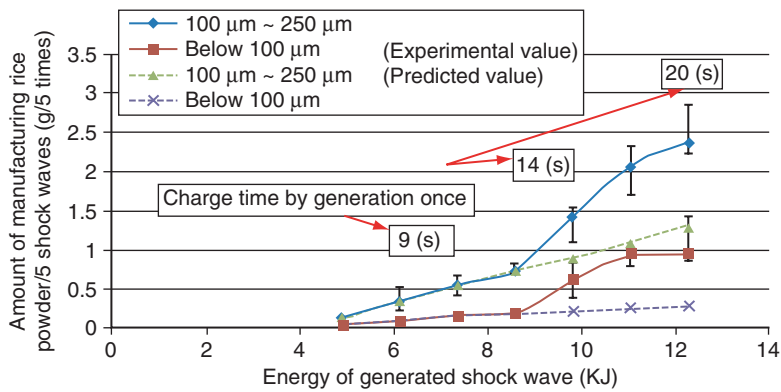

Figure 9 The result of amount of rice-powder manufacturing on batch experiment.

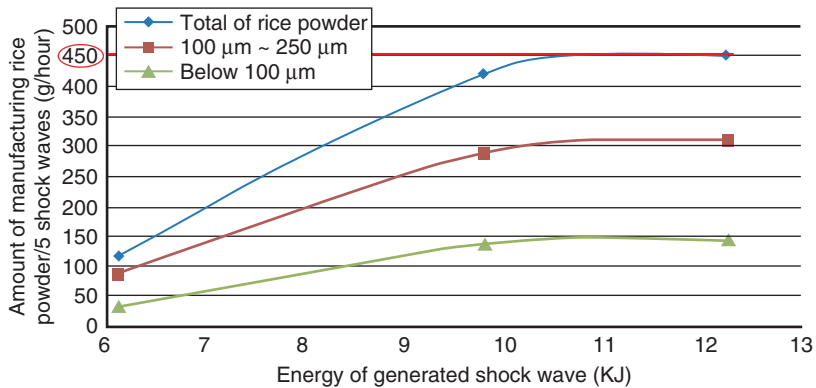

Figure 10 The result of rice-powder manufacturing efficiency.

4. CONCLUSIONS

We developed the rice-powder manufacturing system using under water shock wave. Following shows the conclusion of this paper.

- (1) We develop the rice-powder manufacturing system include five devices. And then, it is confirmed to be able continuously to manufacture the rice-powder.
- (2) It has been cleared that the rice-powder of the grain degree of 10–300 μm obtains 87% of the manufactured rice-powder, and the average grain size of the manufactured rice-powder is 59 μm .
- (3) It is clear that the rice-powder manufacturing efficiency is 450 g/hour.

ACKNOWLEDGEMENT

This study is supported by the Research and Development Projects for Application in Promoting New Policy of Agriculture Forestry and Fisheries (No.24022).

REFERENCES

- [1] S. Tanaka, K. Hokamoto, S. Itoh, Analysis of particle penetration into aluminum plate using underwater shock wave, Proceedings of 15th APS Topical Conference on Shock Compression of Condensed Matter (2007).
- [2] S. P. Marsh, "LANL SHOCK HUGONIOT DATA", University of California Press Berkeley, Los Angeles, London, pp. 573, 1980.

